



**CEPSA Minimizes Hydrogen Losses and Reduces
CO₂ Emissions by Optimizing Refinery Hydrogen
Network with Aspen GDOT™**

“Aspen GDOT clearly fits our company’s strategy to produce energy efficiently.”

-Process Control Engineer, CEPESA

>€450K/year¹
savings from minimizing hydrogen losses

>750 Nm³/hour²
reduction in hydrogen loss

CHALLENGE

- As CEPESA’s La Rábida refinery expanded its capacity, it was becoming increasingly complicated to integrate new units in a coordinated manner for optimal operations.
- Balancing the refinery’s hydrogen network was becoming more complex, leading to higher levels of hydrogen losses to flare and fuel gas networks. Moreover, onsite hydrogen production was highly carbon-intensive.

SOLUTION

- AspenTech’s closed loop multi-unit dynamic optimizer, Aspen GDOT, was implemented to optimize CEPESA’s hydrogen network. Given the complexity of the overall network, the solution was implemented in two phases.
- GDOT’s robust optimizer accounted for all major hydrogen producers, consumers and recovery units with constantly evolving operational situations.
- Minimal maintenance was needed as the online GDOT models calibrated continually and automatically in the background.

VALUE CREATED

- Minimized hydrogen losses and reduced CO₂ emissions in a two-phased approach (see page 6 for detailed breakdown).
- Prioritized and maximized feedstock to key hydrogen consumers, including the recently added bio feedstock co-processing application.

¹ Savings based on 2019 natural gas and hydrogen pricing. Savings would be considerably higher if current 2022 gas and energy prices were used.

² Nm³ = normal cubic meter

Introduction

Compañía Española de Petróleos, S.A.U. (CEPSA) is a multinational energy company with headquarters in Madrid, Spain. It has a presence in five continents and operates across the entire integrated oil and gas value chain. It has been in business for over 90 years and has over 10,000 employees. CEPSA's total distillation capacity is 23.5 metric tons per year, which represents 32% of the installed capacity in Spain. Its refining operations are well integrated with downstream chemicals.

The company has a strong focus on growing its business in a sustainable manner over the long term. CEPSA recently started bio feedstock co-processing, an area of increasing focus, at its La Rábida refinery facility. In 2021, it adopted a five-year decarbonization plan. CEPSA is one of over 50 oil companies from around the world who endorsed the World Bank's "Zero Routine Flaring by 2030" initiative seeking to minimize the negative effects of gas flaring. Endorsing companies have committed to implementing economically viable solutions to eliminate routine flaring (those occurring during normal oil production operations) no later than 2030.



CEPSA's La Rábida Refinery and Hydrogen Network

CEPSA's La Rábida refinery, located in southern Spain, has been in operation since 1967. In 2010, the refinery expanded its capacity significantly from 100,000 BPD to 220,000 BPD. The expansion was one of the largest investments in the company's history.

and steam reformer. There are several consumers, each requiring a different level of hydrogen purity. Its main consumers are hydrocracker, multiple hydrotreaters and petrochemical units (e.g., converting toluene to benzene and converting benzene to cyclohexane).

The refinery's hydrogen network is comprised of several process units and integrated within an adjacent petrochemicals complex. The network has three hydrogen producers: a platformer, aromax (catalytic reformer)

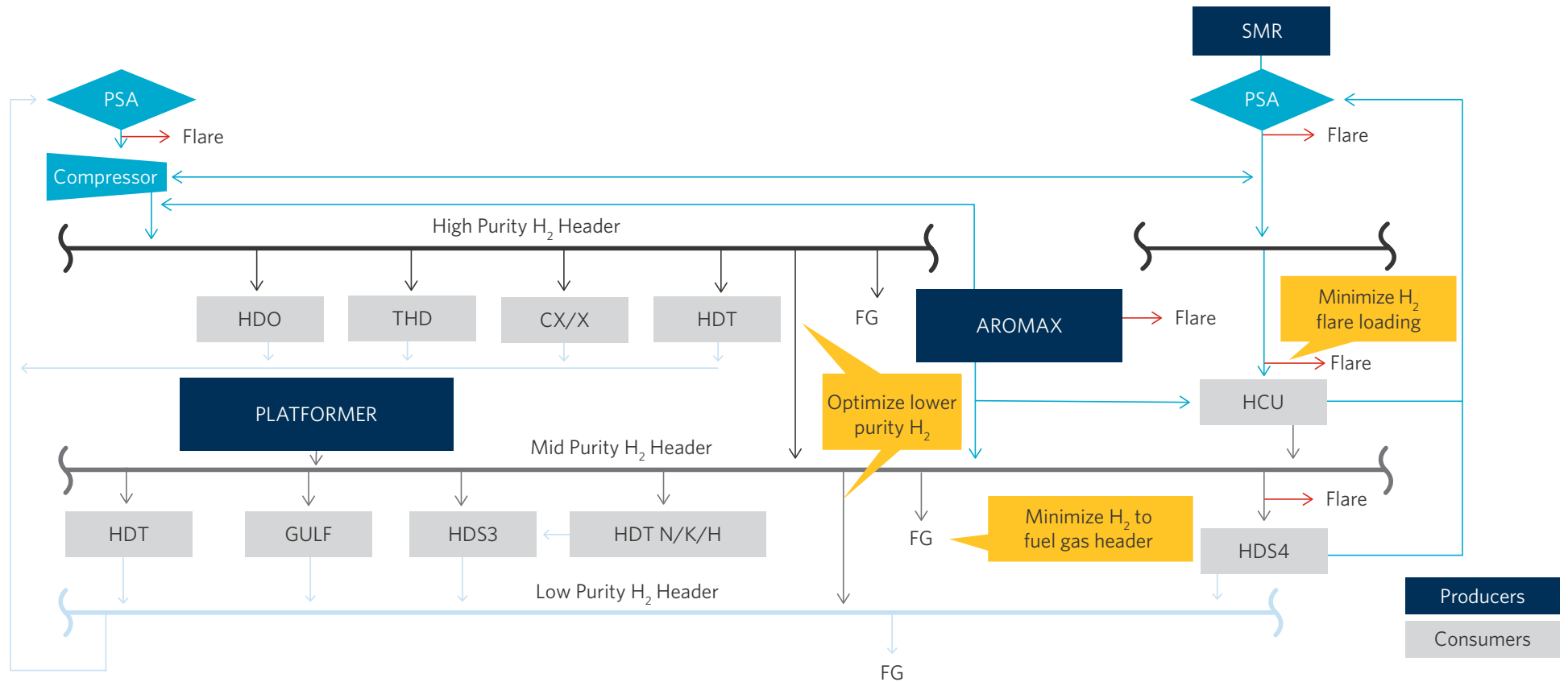

HDS3, HDS4, GULF-Hydrodesulphurization
SMR-Steam Methane Reformer

HDO, HDT N/K/H-Hydrotreaters
PSA-Pressure Swing Adsorption

THD,CX/X-Chemical Units
HCU-Hydrocracker

FG-Fuel Gas



A Priority for CEPSA: Reducing the Impact of its Activity on the Environment

CO₂ emissions and flaring have been a concern in Europe since the Emissions Trading System was put in place in 2005. Those concerns have only increased with more and more attention on climate change and corporate sustainability targets. With limited allotments for each company decreasing annually, there is an increasing focus on efficiency of the hydrogen network and how hydrogen is used.

At the same time, CEPSA is highly committed to reducing emissions with a system that ensures efficiency. Optimizing its hydrogen network enabled CEPSA to meet a number of critically important goals:

- Maximize utilization of hydrocarbon and petrochemical units (depending on economics)
- Minimize hydrogen losses to flare or fuel gas and consequently lower CO₂ emissions from hydrogen production
- Increase hydrogen feed to hydrocracker and other hydrogen-consuming units
- Balance site's hydrogen network, especially important since bio feedstock co-processing typically has a greater hydrogen requirement than fossil-based feedstock
- Relieve load on panel operators to enable focus on more value-adding activities

A Two-Phased GDOT Implementation to Balance the Site's Hydrogen Network

CEPSA selected AspenTech's closed loop multi-unit dynamic optimizer, Aspen GDOT, to optimize its hydrogen network. Given the complexity of the overall network, the solution was implemented in two phases.

The first phase was a steam methane reforming (SMR) application to minimize flaring, done in 2011. It focused on the high purity hydrogen section to reduce flaring by balancing the hydrogen header and modulating the steam reformer (producer), hydrocracker and petrochemical units (consumers). Unit capacities were adjusted based on the hydrogen mix.

Once GDOT was implemented, the average valve open percent value decreased significantly, **reducing hydrogen loss to flare by >250 Nm³/hour (a reduction of over 70%)** and resulting in **savings of approximately €200,000/year¹ and a service factor of >97%**. This equates to a **reduction of approximately 1,400 tons of CO₂/year** (0.5% SMR CO₂ emissions).

The second phase occurred in 2018 when GDOT was commissioned on the rest of the hydrogen network with a goal to reduce hydrogen loss to fuel gas. The system also includes a Pressure Swing Adsorption (PSA) section for hydrogen purification, which recovers hydrogen from the low purity header and is recycled to the PSA section instead of sending to the fuel gas header.

Following the implementation of GDOT, **hydrogen loss to fuel gas was reduced by 500 Nm³/hour (a reduction of up to 80%),** resulting in **savings of approximately €250,000/year¹**. This equates to a **reduction of approximately 2,800 tons of CO₂/year** (if hydrogen was not limited).

GDOT's robust optimizer accounted for all major hydrogen producers, consumers and recovery units with constantly evolving operational situations. There are multiple locations across the entire network from which hydrogen can be sent to the fuel gas header. To prevent hydrogen loss to fuel gas, it was not enough to just balance the hydrogen network. Moving hydrogen to different parts of the network, from areas of hydrogen accumulation to depletion, through pressure differential or through compressors, was equally important.

GDOT also delivered great value to CEPSA'S bio feedstock co-processing initiative by providing a clear understanding of how hydrogen was being utilized and highlighting any restrictions. This helped the company easily prioritize what they needed to maximize (e.g., hydrogen for bio feedstock co-processing feeds, other hydrogen consumer feeds etc.).



“We have been able to integrate all the different systems (within the hydrogen network) really well to get tangible benefits.”

-Process Control Engineer, CEPSA

Added Value: Maximized Feed and Improved Operational Agility

In addition to minimizing hydrogen losses, feed of hydrogen to key consumers was maximized. For example, GDOT increased the cyclohexane unit feed by almost 10% or an equivalent of 1% increase in feed to hydrocracker, when the system was limited by available hydrogen.

Under volatile market conditions, with elevated pricing for hydrogen and CO₂ emissions credits, GDOT helped CEPSA quickly and effectively adapt to the changing economic situation.

GDOT enabled modulation of the feed rate as well as the source (and subsequently the purity) of hydrogen to the hydrocracker, depending on the unit's margin. By running high purity hydrogen producer, SMR, at minimal capacity and swapping a portion of the hydrogen supply to the hydrocracker with lower purity hydrogen producers, GDOT continued to maximize margins in an environment of high hydrogen and natural gas prices. Balancing the hydrogen network in this manner without GDOT would not be easy.

Another benefit of using GDOT was that minimal maintenance work was needed as the online models calibrated continuously and automatically in the background, with patented dynamic data reconciliation technology enabling existing APC resources to run and maintain them.

“Since GDOT’s implementation in 2018, we are quite happy with its behavior. We are seeing significant benefits.”

-Process Control Engineer, CEPSA





In addition to providing tremendous economic benefit to CEPSA, GDOT has positively impacted La Rábida refinery's operations in the following ways:

- Reduced carbon emissions significantly
- Resulted in superior operational execution of the refinery's plan
- Enabled easy coordination and optimization of multiple units
- Easily understood by unit operators

Despite CEPSA having a few initial concerns about GDOT's agility and maintainability, any worries were quickly allayed once the application was up and running. "When you must add or modify a unit, GDOT acts fast for fast results," says the company's process control engineer. "The primary work is with the DCS and APC revamps. It's greatly appreciated that GDOT, despite it being a rather large application, is actually low maintenance. We are very pleased with the significant impact that GDOT is having on our operations."





About Aspen Technology

Aspen Technology, Inc. (NASDAQ: AZPN) is a global software leader helping industries at the forefront of the world's dual challenge meet the increasing demand for resources from a rapidly growing population in a profitable and sustainable manner. AspenTech solutions address complex environments where it is critical to optimize the asset design, operation and maintenance lifecycle. Through our unique combination of deep domain expertise and innovation, customers in capital-intensive industries can run their assets safer, greener, longer and faster to improve their operational excellence.

[aspentech.com](https://www.aspentech.com)

© 2022 Aspen Technology, Inc. All rights reserved. AT-07675

